

Fantom XR

SAMPLE TOOLS EXPANSION

Guide to the Added Functionality

Before using this unit, carefully read the sections entitled: "USING THE UNIT SAFELY" and "IMPORTANT NOTES" (p. 3; p. 4). These sections provide important information concerning the proper operation of the unit. Additionally, in order to feel assured that you have gained a good grasp of every feature provided by your new unit, this guide should be read in its entirety. This guide should be saved and kept on hand as a convenient reference.

This guide applies to the Fantom-XR and FANTOM-XR Sample Tools Expansion Kit.

Customers who purchased the "FANTOM-XR Sample Tools Expansion Kit" (update card):

You must first update your Fantom-XR. Begin reading from "Check the contents of the package" (p. 6).

Customers who purchased the Fantom-XR (Synthesizer/Sampler module):

You don't need to update your Fantom-XR. Begin reading from "Main features" (p. 10).

Copyright © 2005 ROLAND CORPORATION

All rights reserved. No part of this publication may be reproduced in any form without the written permission of ROLAND CORPORATION.

Information

When you need repair service, call your nearest Roland Service Center or authorized Roland distributor in your country as shown below.

AFRICA

EGYPT

Alamy Trading Office
9, ERN Hagar Al Askalany
Street,
ARD El Golf, Helipolis,
Cairo 11341, EGYPT
TEL: 20-2 417-1828

REUNION

YAM Marcel
25 Rue Jules Hermann,
Chaudron - BP79 97 491
Ste Clotilde Cedex,
REUNION ISLAND
TEL: (0262) 218-429

SOUTH AFRICA

That Other Music Shop (PTY) Ltd.
11 Melle St., Braamfontein,
Johannesburg,
SOUTH AFRICA
TEL: (011) 403 4105
FAX: (011) 403 1234

Paul Bothner (PTY) Ltd.
17 Werdmuller Centre,
Main Road, Claremont 7708
SOUTH AFRICA
TEL: (021) 674 4030

ASIA

CHINA

Roland Shanghai Electronics
Co., Ltd.
5F, No.1500 Pingliang Road
Shanghai 200090, CHINA
TEL: (021) 5880-0800

Roland Shanghai Electronics
Co., Ltd.
(BEIJING OFFICE)
10E, No.18 3 Section Anhuaxi
Chaoyang District Beijing
100011 CHINA
TEL: (010) 6426-5050

Roland Shanghai Electronics
Co., Ltd.
(GUANGZHOU OFFICE)
2/F, No. 31 You Nan Er Jie
Yi Xiang, Wu Yang Xin Cheng,
Guangzhou 510600, CHINA
TEL: (020) 8736-0428

HONG KONG

Ton Lee Music Co., Ltd.
Service Division
22-32 Pun Shan Street, Tseun
Wan, New Territories,
HONG KONG
TEL: 2415 0911

Parsons Music Ltd.
8th Floor, Railway Plaza, 39
Chatham Road South, T.S.T.,
Kowloon, HONG KONG
TEL: 2333 1863

INDIA
Rivena Digicel (India) Pvt. Ltd.
409, Nirman Kendra
Mahalaxmi Flats Compound
Off. Dr. Edwin Moses Road,
Mumbai-400011, INDIA
TEL: (022) 2493 9051

INDONESIA
PT Citra Inti Rama
Jl. Cideng Timur No. 15f-150
Jakarta Pusat
INDONESIA
TEL: (021) 6324170

KOREA
Cosmos Corporation
1461-9, Secho-Dong,
Secho Ku, Seoul, KOREA
TEL: (02) 3486-8885

MALAYSIA

Roland Asia Pacific Sdn. Bhd.
45-1, Block C2, Jalan PPU 1/39,
Dataran Prima, 47301 Petaling
Jaya, Selangor, MALAYSIA
TEL: (03) 7805-3263

PHILIPPINES

G.A. Yupanog & Co. Inc.
2399 CagI, Puyat Avenue
Makati, Metro Manila 1200,
PHILIPPINES
TEL: (02) 899 9801

SINGAPORE

SWE LEE MUSIC
COMPANY PTE. LTD.
150 Sims Drive,
SINGAPORE 387381
TEL: 6846-3676

CRISTOFORI MUSIC PTE LTD
Blk 304, Bedok Industrial Park E,
402-2148, SINGAPORE 489980
TEL: 6243-9555

TAIWAN

ROLAND TAIWAN
ENTERPRISE CO., LTD.
Room 5, 9F, No. 112 Chung
Shan N. Road Sec. 2, Taipei,
TAIWAN, R.O.C.
TEL: (02) 2561 3339

THAILAND

Thera Music Co., Ltd.
330 Veang NakornKasem, Soi 2,
Bangkok 10100, THAILAND
TEL: (02) 2248821

VIETNAM

Saigon Music
Suite DP-8
40 Ba Huyen Thanh Quan Street
Hochiminh City, VIETNAM
TEL: (08) 930-1969

AUSTRALIA/ NEW ZEALAND

AUSTRALIA/ NEW ZEALAND

Roland Corporation
Australia Pty. Ltd.
38 Campbell Avenue
Dee Why NSW 2099
AUSTRALIA
For Australia
TEL: (02) 9982 8266
For New Zealand
TEL: (09) 3098 715

For Australia
TEL: (02) 9982 8266
For New Zealand
TEL: (09) 3098 715

CENTRAL/LATIN AMERICA

ARGENTINA

Instrumentos Musicales S.A.
Av Santa Fe 2055
ARGENTINA
TEL: (011) 4508-2700

BARBADOS

A&B Music Supplies LTD
12 Webster Industrial Park
Wildey, St. Michael, Barbados
TEL: (246) 430-1100

BRAZIL

Roland Brasil Ltda.
Rua San Jose, 780 Sala B
Parque Industrial San Jose
Cota Sa Paulo - SP, BRAZIL
TEL: (011) 4615 5666

CHILE

Comercial Fanco II S.A.
Rut.: 96.919.420-1
Natalmi Cox #739, 4th Floor
Santiago - Centro, CHILE
TEL: (02) 688-9540

COLOMBIA

Centro Musical Ltda.
Cra 43 B No 25 A 41 Bodega 9
Medellin, Colombia
TEL: (574) 3812529

COSTA RICA

JUAN Bansaeb Instrumentos
Gr. 1. Calle 11, Apartado 10237,
San Jose, COSTA RICA
TEL: 258-0221

CURACAO

Zeelandia Music Center Inc.
Orionweg 30
Curacao, Netherland Antilles
TEL: (00593) 926866

DOMINICAN REPUBLIC

Instrumentos Fernando Giraldez
Calle Proyecto Central No.3
Ens La Esperilla
Santo Domingo,
Dominican Republic
TEL: (809) 683 0305

ECUADOR

Mus Asukia
Rumichaca 822 y Zaruma
Guayaquil - Ecuador
TEL: (593-4) 2302364

EL SALVADOR

OMNI MUSIC
75 Avenida Norte y Final
Alameda Juan Pablo II,
Edificio No. 4010 San Salvador,
EL SALVADOR
TEL: 262-0788

GUATEMALA

Casa Instrumental
Calleza Roosevelt 34-01, zona 11
Ciudad de Guatemala
Guatemala
TEL: (502) 599-2888

HONDURAS

Almaejan Pajaro AZ S.A. de C.V.
B.O. Paz Barahona
3 Ave. 11 Calle S.O
San Pedro Sula, Honduras
TEL: (504) 553-2029

MARTINIQUE

Musique & Son
Z.I Les Mangle
97232 Le Lamentin
Martinique F.W.I.
TEL: 596 596 426860

Gigamusic SARL
10 Rue De La Folie
97200 Fort De France
Martinique F.W.I.
TEL: 596 596 71522

MEXICO

Casa Veerkamp, s.a. de c.v.
Av. Toluca No. 323, Col. Olivar
de los Padres 01780 Mexico
D.F. MEXICO
TEL: (55) 5668-6095

NICARAGUA

Bansaeb Instrumentos
Musicales Nicaragua
Alumina D'Este Calle Principal
de la Farmacia 25 Avenida
11 Cuadra al Lago #013
Managua, Nicaragua
TEL: (505) 277-2557

PANAMA

SUPRO MUNDIAL, S.A.
Boulevard Andros, Albrook,
Panama City, REP. DE
PANAMA
TEL: 315-5011

PARAGUAY

Distribuidora De
Instrumentos Musicales
J.E. Oleary Y EQ, Manduvira
Asuncion PARAGUAY
TEL: (595) 21 492147

PERU

Audionet
Distribuciones Musicales SAC
Juan Fanning 530
Miraflores
Lima - Peru
TEL: (51) 4461388

TRINIDAD

AMR Ltd
Gr. 2nd Floor
Maritime Plaza
Barataria Trinidad W.L.
TEL: (868) 638 6385

URUGUAY

Todo Musica S.A.
Francisco Acuna de Figueroa
177
C.P.: 11. 800
Montevideo, URUGUAY
TEL: (02) 924-2335

VENEZUELA

Instrumentos Musicales
Allegro, C.A.
Av. las industrias edif. Gutar
Import
#7 Zona Industrial de Turumo
Caracas, Venezuela
TEL: (212) 244-1122

EUROPE

AUSTRIA

Roland Elektronische
Musikinstrumente GmbH.
Austrian Office
Eduard-Bodern-Gasse 8,
A-6020 Innsbruck, AUSTRIA
TEL: (0512) 26 44 260

BELGIUM/FRANCE/ HOLLAND/ LUXEMBOURG

Roland Central Europe N.V.
Houtstraat 3, B-2260, Oevel
(Westerlo) BELGIUM
TEL: (014) 575811

CZECH REP.

K-AUDIO
Kardasovska 626,
CZ-198 00 Praha 9,
CZECH REP.
TEL: (2) 666 10529

DENMARK

Roland Scandinavia A/S
Nostvangenvej 7, Postboks 880,
DK-2100 Copenhagen
Denmark
TEL: 3916 6200

FINLAND

Roland Scandinavia As, Filial
Finland
Elanontie 5
FIN-01510 Vantaa, FINLAND
TEL: (09 68 24 20)

GERMANY

Roland Elektronische
Musikinstrumente GmbH.
Oststrasse 96, 22844
Norderstedt, GERMANY
TEL: (400) 52 6090

GREECE

STOLLAS S.A.
Music Sound Light
155, New National Road
Patras 26442, GREECE
TEL: 2610 435400

HUNGARY

Roland East Europe Ltd.
Warehouse Area "DEPO" P/83
H-2046 Tokorhalmt,
HUNGARY
TEL: (23) 511011

IRELAND

Roland Ireland
C2 Calmout Park, Calmout
Avenue, Dublin 12
Republic of Ireland
TEL: (01) 4294444

ITALY

Roland Italy S. P. A.
Viale delle Industrie 8,
20020 Arese, Milano, ITALY
TEL: (02) 937-78300

NORWAY

Roland Scandinavia Avd.
Kantor Norge
Lilleakerveien 2 Postboks 95,
Lilleaker No-0216 Oslo
NORWAY
TEL: 2273 0074

POLAND

MX MUSIC SP.Z.O.O.
177
PL-03664 Warszawa POLAND
TEL: (022) 679 44 19

PORTUGAL

Roland Iberia, S.L.
Portugal Office
Cais das Pedras, 8/9-1
4050-465, Porto, PORTUGAL
TEL: 22 608 01 60

ROMANIA

FBS LINES
Piata Libertatii 1,
535500 Gheorgheni,
ROMANIA
TEL: (266) 364 609

RUSSIA

MuTeK
3-Bogoytrskaya Str. 1.k1
107 564 Moscow, RUSSIA
TEL: (095) 169 5043

SPAIN

Roland Iberia, S.L.
Paseo Garcia Faria, 33-05
08005 Barcelona SPAIN
TEL: 93 493 91 00

SWEDEN

Roland Scandinavia A/S
SWEDISH SALES OFFICE
Danvik Center 25, 2. U.
S-131 30 Nacka SWEDEN
TEL: (08) 702 00 20

SWITZERLAND

Roland (Switzerland) AG
Landstrasse 5, Postfach,
CH-4452 Hingen,
SWITZERLAND
TEL: (061) 927-8383

UKRAINE

TIC-TAC
Mira Str. 19/108
P.O. Box 180
295400 Mukachevo,
UKRAINE
TEL: (09313) 414-40

UNITED KINGDOM

Roland (U.K.) Ltd.
Atlantic Close, Swansea
Enterprise Park, SWANSEA
SA7 9EJ,
UNITED KINGDOM
TEL: (01792) 702701

MIDDLE EAST

BAHRAIN

Moon Stores
No.16, Bab Al Bahrain Avenue,
P.O.Box 247, Manama 304,
State of BAHRAIN
TEL: 17 211 005

CYPRUS

Radox Sound Equipment Ltd.
17, Diagorou Street, Nicosia,
CYPRUS
TEL: (022) 66-9426

IRAN

MOCO INC.
No.41 Nike St., D-Shariyati Ave.,
Roboroye Cerah Mirzadad
Tehran, IRAN
TEL: (021) 285-4169

ISRAEL

Hatili P. Greenspan & Sons Ltd.
8 Ketzif Ha aliya Hashnya St.
Tel-Aviv Yafo ISRAEL
TEL: (03) 6823666

JORDAN

AMMAN Trading Agency
245 Prince Mohammad St.,
Amman 1118, JORDAN
TEL: (06) 464-1200

KUWAIT

EASA HUSAIN AL-YOUSIFI
& SONS CO.
Abdullah Salem Street,
Safat, KUWAIT
TEL: 262 6399

LEBANON

Chahine S.A.L.
George Zeidan St., Chahine
Bldg., Achrafieh, P.O.Box: 16-
5857
Beirut, LEBANON
TEL: (01) 20-1441

OMAN

TALENIZ CENTRE L.L.C.
P.O. BOX 37, MUSCAT,
POSTAL CODE 113
TEL: 931-3705

QATAR

Al Emadi Co. (Badie Studio &
Stores)
P.O. Box 62, Doha, QATAR
TEL: 4423-554

SAUDI ARABIA

ADawiah Universal
Electronics APL
Corniche Road, Aldossary
Bldg., 1st Floor, AlKhobar,
SAUDI ARABIA
P.O.Box 2154, AlKhobar 31952
SAUDI ARABIA
TEL: (03) 898 2081

SYRIA

Technical Light & Sound
Center
Rawda, Abdul Qader Jazairi St.
Blg. No. 21, P.O. BOX 13520,
Damascus, SYRIA
TEL: (011) 223-5384

TURKEY

Ast Muzik Aletleri Ithalat Ve
Ihracat Ltd Sti
Sirasivler Caddesi
Sirasivler Pasaji No:74/20
Taksim - Istanbul, TURKEY
TEL: (0212) 2449624

U.A.E.

Zak Electronics & Musical
Instruments Co. L.L.C.
Zabeel Road, Al Sheeroq Bldg.,
No. 14, Grand Floor, Dubai,
U.A.E.
TEL: (04) 3360715

NORTH AMERICA

CANADA

Roland Canada Music Ltd.
(Head Office)
5480 Parkwood Way
Richmond B.C., V6V 2M4
CANADA
TEL: (604) 270 6626

CANADA



Roland Canada Music Ltd.
(Toronto Office)
17 Admiral Boulvard
Mississauga On L5T 2N6
CANADA
TEL: (905) 362 9707



U. S. A.

Roland Corporation U.S.
5100 S. Eastern Avenue
Los Angeles, CA 90044-2938,
U. S. A.
TEL: (323) 890 3700







USING THE UNIT SAFELY

INSTRUCTIONS FOR THE PREVENTION OF FIRE, ELECTRIC SHOCK, OR INJURY TO PERSONS

About  WARNING and  CAUTION Notices





 WARNING	Used for instructions intended to alert the user to the risk of death or severe injury should the unit be used improperly.
 CAUTION	Used for instructions intended to alert the user to the risk of injury or material damage should the unit be used improperly. * Material damage refers to damage or other adverse effects caused with respect to the home and all its furnishings, as well to domestic animals or pets.

About the Symbols





	The  symbol alerts the user to important instructions or warnings. The specific meaning of the symbol is determined by the design contained within the triangle. In the case of the symbol at left, it is used for general cautions, warnings, or alerts to danger.
	The  symbol alerts the user to items that must never be carried out (are forbidden). The specific thing that must not be done is indicated by the design contained within the circle. In the case of the symbol at left, it means that the unit must never be disassembled.
	The  symbol alerts the user to things that must be carried out. The specific thing that must be done is indicated by the design contained within the circle. In the case of the symbol at left, it means that the power-cord plug must be unplugged from the outlet.

ALWAYS OBSERVE THE FOLLOWING

WARNING

- Before using this unit, make sure to read the instructions below, and the Guide to the Added Functionality. 
- Do not open or perform any internal modifications on the unit. 
- Do not attempt to repair the unit, or replace parts within it (except when this guide provides specific instructions directing you to do so). Refer all servicing to your retailer, the nearest Roland Service Center, or an authorized Roland distributor, as listed on the "Information" page. 
- Never use or store the unit in places that are:
 - Subject to temperature extremes (e.g., direct sunlight in an enclosed vehicle, near a heating duct, on top of heat-generating equipment); or are 
 - Damp (e.g., baths, washrooms, on wet floors); or are 
 - Humid; or are
 - Exposed to rain; or are
 - Dusty; or are
 - Subject to high levels of vibration.

WARNING

- Do not allow any objects (e.g., flammable material, coins, pins); or liquids of any kind (water, soft drinks, etc.) to penetrate the unit. 

- In households with small children, an adult should provide supervision until the child is capable of following all the rules essential for the safe operation of the unit. 
- Protect the unit from strong impact. (Do not drop it!) 
- DO NOT play a CD-ROM disc on a conventional audio CD player. The resulting sound may be of a level that could cause permanent hearing loss. Damage to speakers or other system components may result. 

CAUTION

- Never climb on top of, nor place heavy objects on the unit. 

Important Notes

In addition to the items listed under “USING THE UNIT SAFELY” on page 3, please read and observe the following:

Placement

- Do not expose the unit to direct sunlight, place it near devices that radiate heat, leave it inside an enclosed vehicle, or otherwise subject it to temperature extremes. Excessive heat can deform or discolor the unit.

Before Using Cards

Using DATA Cards

- Insert the CompactFlash card correctly into the PC card adapter, and insert it all the way into the PC card slot.

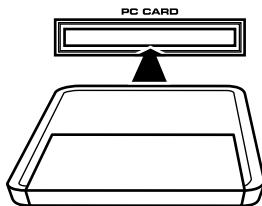

- Never touch the terminals of the CompactFlash and PC card adapter. Also, avoid getting the terminals dirty.

Handling CD-ROMs

- Avoid touching or scratching the shiny underside (encoded surface) of the disc. Damaged or dirty CD-ROM discs may not be read properly. Keep your discs clean using a commercially available CD cleaner.

Other Notes

- * All product names mentioned in this document are trademarks or registered trademarks of their respective owners.

- * CompactFlash and  are trademarks of SanDisk Corporation and licensed by CompactFlash association.

- * In the interest of product improvement, the specifications and/or contents of this package are subject to change without prior notice.

- * In this guide, we use the term “Owner's Manual” for you to refer to the “Fantom-XR Owner's Manual”.

Contents

Check the contents of the package	6
Updating the FANTOM-XR	7
What is the FANTOM-XR Sample Tools Expansion Kit?	7
Items required for performing the update	7
Cautions when performing the update (Important)	7
Update procedure	8
Verifying the update	9
Main features	10
Multisample editing functions	11
Creating a multisample	11
Creating a multisample in the Patch Edit screen	12
Creating a multisample in the Create Multisample screen	12
Editing a multisample	13
About the Multisample Edit screen	13
Moving the split point	13
Selecting the notes to edit	13
Auditioning a note (Preview)	13
Changing the multisample assigned to a tone (Multisample List)	14
Assigning a sample to the selected region (Assign)	14
Erasing the data from the selected region of notes (Erase)	14
Replacing the sample of the current zone (Sample Select)	14
Specify the original key of the sample (Original Key)	15
Sorting samples in the order of their original key (Sort)	15
Returning a multisample to the last-written state (Reload)	15
Erasing all notes (Erase All)	16
Opening the Tone Select window (Tone Select)	16
Saving a multisample	17
Sample-related changes	18
Extended patch groups	18
Saving a sample auto patch	18
Bank Select and Program Change Correspondence Chart	18
Newly added sample parameters	19
Changes due to the upgraded editor software	20
Newly added PC mode screen	20
Cautions when using S-700 series sounds with the FANTOM-XR	20
Before you connect the FANTOM-XR to your computer	20
Importing patches and rhythm sets	21
Fantom-X Editor System Requirements	23
Other changes	24
Changes in the librarian	24
Newly added DIMM check function	24
Saving samples (Save All Samples)	24
Index	25

Check the contents of the package

This package contains the following items. As soon as you open the package, please make sure that all items are present. You may wish to check off () each box as you verify each item. If anything is missing, please contact your dealer.

* *This page is for verifying the contents of the FANTOM-XR Sample Tools Expansion Kit (update card). If you purchased the FANTOM-XR (synthesizer/sampling module), please begin reading from "Main features" (p. 10).*

FANTOM-XR Sample Tools Expansion Kit CompactFlash card

For the update procedure, refer to "Updating the FANTOM-XR" (p. 7).

PC card adapter

This adapter allows the "FANTOM-XR Sample Tools Expansion Kit" CompactFlash card to be inserted into the Fantom-XR sound module.

CD-ROM (Editor)

Fantom-XR Sound List (Leaflet)

Guide to the Added Functionality (this document)

This is the document you are reading. It explains the functionality added by the FANTOM-XR Sample Tools Expansion.

Sticker

Updating the FANTOM-XR

What is the FANTOM-XR Sample Tools Expansion Kit?

The FANTOM-XR Sample Tools Expansion Kit consists of a CompactFlash card containing an upgrade program that enhances the multisample functionality, together with a PC card adapter for inserting this card into your Fantom-XR.

Once you perform the update procedure, the Fantom-XR will always start up with the added FANTOM-XR Sample Tools Expansion functionality.

NOTE

Keep this product in a safe place after you have completed the upgrade.

Items required for performing the update

- “FANTOM-XR Sample Tools Expansion Kit” CompactFlash card and PC card adapter (hereafter referred to as “this product”)
- Fantom-XR synthesizer/sampling module

NOTE

Use only the CompactFlash card and PC card adapter included with this product.

Cautions when performing the update (Important)

- Never use this product with any device other than the Fantom-XR. Doing so may damage the data or system of this product or of the other device.
- Do not turn off the power while the update is in progress. Doing so may render the Fantom-XR incapable of starting up correctly.
- As a precaution, we recommend that you back up your user data before you begin. (Owner’s Manual; p. 162)
- Do not format this product on the Fantom-XR or on any other device.
- Please note that once you have completed the update using this product, it will not be possible to return the Fantom-XR to its prior version.
- Once you have completed the update, do not insert this product into the Fantom-XR.

The files contained in this product may not be reproduced, modified, or included in any magazine or commercial product without the permission of Roland Corporation.

Update procedure

1. Insert the “FANTOM-XR Sample Tools Expansion Kit” CompactFlash card into the PC card adapter.

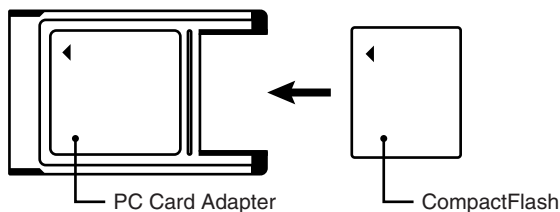

2. Make sure that your Fantom-XR is switched OFF.
3. Insert the PC card adapter (see step 1) into the Fantom-XR.
4. Switch ON the power on your Fantom-XR.

After the opening movie is displayed, a caution regarding the update procedure will appear.

- * If the screen shown below does not appear, switch off the Fantom-XR’s power, and repeat the operation from step 1.



5. Read the warning, and if you wish to proceed, press ▶ .

Press ▶ several times to view and read the entire message.
A screen will ask you for confirmation.

- * If you wish to abort the update procedure at this point, press [EXIT], turn off the power, and remove the PC card.

6. Press [ENTER] to execute the update.

- * Do not turn off the power while the update is in progress.
- * The update will require approximately two minutes for completion.

7. When the process has been completed, the display will indicate “Completed.” Turn off the power of the Fantom-XR and remove the PC card.

This completes the update.

The next time you turn on the power, the FANTOM-XR Sample Tools Expansion will start up.

MEMO

Keep this product in a safe place after you have completed the upgrade.

Verifying the update

1. In the Patch Play screen (Owner's Manual; p. 40) or the Performance Play screen (Owner's Manual; p. 84), press [MENU].

The Top Menu screen will appear.

2. Press ▲ or ▼ to select "System," and then press [ENTER].

The System Setup screen will appear.

3. Use ◀ or ▶ to select "System Version Info."

Verify that the version indication reads "Version 2.**" (2.00 or higher).

Main features

The Fantom-XR Sample Tools Expansion adds sample tools, providing a significant leap in music-making power. With its comprehensive unification of synth, sampler, and audio functionality, the Fantom-XR is reborn as an even more powerful synthesizer/sampler module.

Sample Editor, Multisample Editor, and S-700 series sample converter (p. 20)

Now you can use your computer to easily edit samples.

Multisamples can also be edited, greatly enhancing the potential of the Fantom-XR's music creation abilities.

Additionally, you can now load S-700 series data.

Sample Auto Patch function (p. 18)

As with patches and rhythm sets, you can now easily select samples from the patch list as well. New sample parameters have also been added, making it much easier to handle samples.

Multisample editing (p. 11)

The new Multisample Edit screen lets you easily create and edit multisamples.

New patches

* *128 new patches have been added.*

In order to take full advantage of its enhanced functionality, please read this guide carefully.

Multisample editing functions

cf.

Owner's Manual; p. 126

The FANTOM-XR Sample Tools Expansion adds a Multisample Edit screen that makes it easy to create and edit multisamples.

Creating a multisample

A "multisample" is a set of different samples assigned to the notes of the keyboard. One multisample can split up to 128 samples across the keyboard. You can store 128 multisamples in user memory, and another 128 multisamples in a memory card.

* *In order to hear a multisample, you must assign it to a patch.*

How patches, multisamples, and samples are related

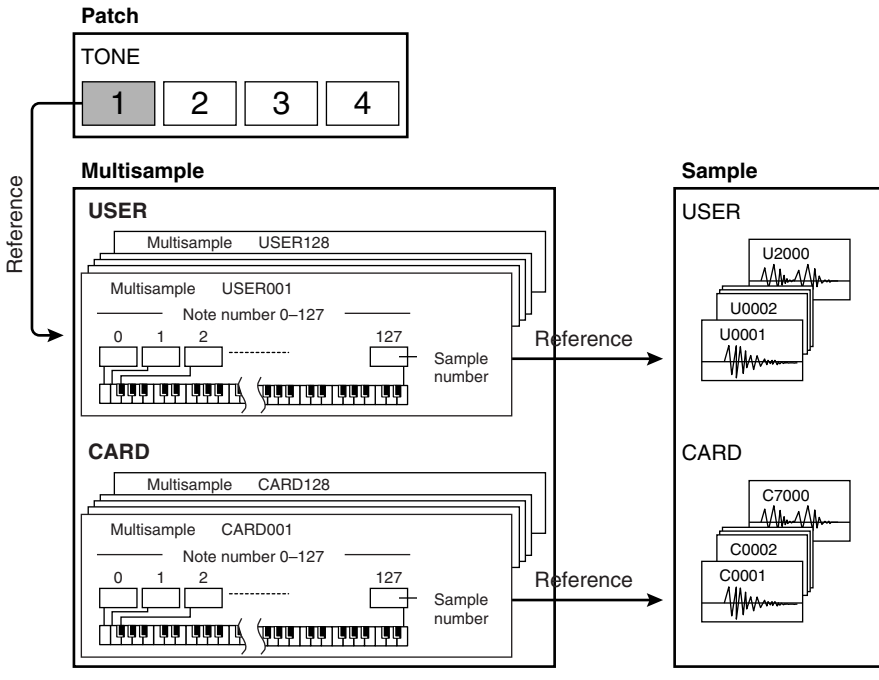

NOTE

User multisamples consist only of user samples, and card multisamples consist only of samples on the card.

Creating a multisample in the Patch Edit screen

MEMO

You should start by initializing the patch settings. (Owner's Manual; p. 69)

1. Press [MODE] so the button lights in red.

You will enter Patch mode, and the Patch Play screen will appear.

MEMO

You can't create a multisample if the patch type is "Rhythm."

2. Press [SHIFT] so it lights, and then press ▼.

The Patch Edit Menu screen will appear.

3. Turn the VALUE dial or use [CURSOR] to select the edit group (Patch WG) of the tone to which you want to assign a multisample.

Example: if assigning a multisample to Tone 2



4. Press the VALUE dial or [ENTER].

The Patch Edit screen will appear.

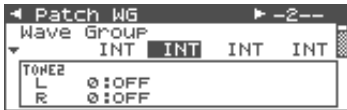

5. Change the parameters as follows to assign a multisample to the selected tone.

- Wave Group: MSAM (Multisample waveforms)
- Wave Bank: USER or CARD
- Wave No. L (Mono): Multisample number

- * For details on making this setting, refer to "How to Make Patch Settings" (Owner's Manual; p. 46).
- * If you want to use a stereo multisample, specify the same number for L and R.

6. Press [MENU].

The Patch Utility screen will appear.

7. Use ▲ or ▼ to select "Multisample Edit."

8. Press [ENTER].

The Multisample Edit screen will appear.

- * For details on editing, refer to "Editing a multisample" (p. 13).

9. Save the multisample.

- * For details on how to save, refer to "Saving a multisample" (p. 17).

10. Save the patch.

- * For details on how to save the patch, refer to "Saving Patches You've Created (Write)" (Owner's Manual; p. 69).

Creating a multisample in the Create Multisample screen

1. As described in steps 1–10 of "Creating a Patch from Multiple Samples (Create Multisample)" (Owner's Manual; p. 126), create a multisample and then create a patch.

The Multisample Edit screen will appear.

- * For details on editing, refer to "Editing a multisample" (p. 13).

2. Save the multisample.

- * For details on how to save, refer to "Saving a multisample" (p. 17).

3. Save the patch.

- * For details on how to save a patch, refer to "Saving Patches You've Created (Write)" (Owner's Manual; p. 69).

Editing a multisample

About the Multisample Edit screen

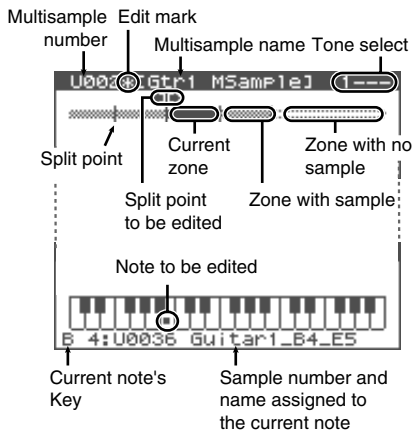

Moving the split point

The "Split Point" is the boundary between zones (p. 14).

1. In the Multisample Edit screen, press **◀** or **▶** to select the split point.

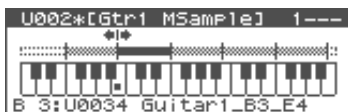

2. Press **[INC]** or **[DEC]** to move the split point.

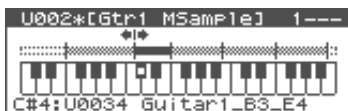

Selecting the notes to edit

1. Turn the **VALUE** dial to select the note you want to edit.

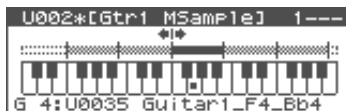

By pressing the **VALUE** dial as you turn it, you can select a range of multiple notes.



You can also select a note by playing an external MIDI keyboard. To select a range of multiple notes, hold down the two outer notes of the desired range.

Auditioning a note (Preview)

1. Turn the **VALUE** dial to select the note.
2. Press the **OUTPUT** knob.

You will hear the sample that's assigned to the note you selected in step 1.

Press the **OUTPUT** knob once again to stop the sound.

Changing the multisample assigned to a tone (Multisample List)

Here's how you can change the multisample that's assigned to the current tone.

- In the Multisample Edit screen, press [SHIFT] so it lights, and then press ◀. The Multisample List window will open.



- Press ◀ or ▶ to select the group where the multisample is saved.
 - * You can also use [GROUP].

USER: User
CARD: Memory card
- Use ▲ or ▼ to select a multisample.
- Press [ENTER].

Assigning a sample to the selected region (Assign)

- In the Multisample Edit screen, select the note(s) where you assign the sample.

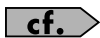

"Selecting the notes to edit" (p. 13)

- Press [MENU].
- Use ▲ or ▼ to select "Assign."
- Press [ENTER].

Sample Select screen will appear.

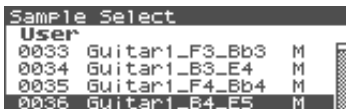

- Use ▲ or ▼ to select the sample to be assigned.
- Press [ENTER].
To cancel, press [EXIT].

Erasing the data from the selected region of notes (Erase)

- In the Multisample Edit screen, select the note(s) to be erased.



"Selecting the notes to edit" (p. 13)

- Press [MENU].
- Use ▲ or ▼ to select "Erase."
- Press [ENTER].

The data for the selected region of notes will be erased.

Replacing the sample of the current zone (Sample Select)

A "zone" is a region to which the same sample is assigned. Here's how to assign a sample to the currently selected zone (the "current zone").

- In the Multisample Edit screen, press ◀ or ▶ to select the current zone.

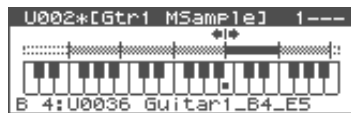

- Press [MENU].
- Use ▲ or ▼ to select "Sample Select."
- Press [ENTER].

The Sample Select screen will appear.

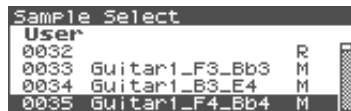

- Use ▲ or ▼ to select the sample to be assigned.
- Press [ENTER].

To cancel, press [EXIT].

Specify the original key of the sample (Original Key)

Samples you record or import are set so that they will play at their original pitch when you press the C4 note.

In order to correctly match the key of the sample to the keyboard, you must modify the “original key” of the sample. For example, if you sampled a sound whose pitch was E4, you’ll need to change its “original key” setting to E4 so that it will play at its original pitch when you press the E4 note of the keyboard.

Similarly, when you execute Create Multisample, you will need to specify the original key of the samples that make up that multisample, so that they are correct for the keys to which they are assigned.

* A sample will not play more than two octaves higher than its original key.

1. In the Multisample Edit screen, press **◀** or **▶** select the current zone.

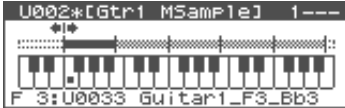

2. Press **[SHIFT]** so it lights, and then press **▼**.

Or press **[ENTER]**.

The Original Key window will open.

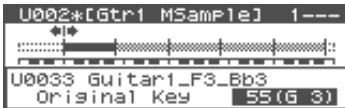

3. Turn the VALUE dial or press **[INC]** or **[DEC]** to change the original key of the sample assigned to the zone.

4. Press **[EXIT]**.

You’ll be returned to the Multisample Edit screen.

5. Save the sample whose original key you changed.

* For details on saving a sample, refer to “Saving a Sample” (Owner’s Manual; p. 131).

Sorting samples in the order of their original key (Sort)

This operation reassigns all samples currently assigned to the multisample, so that they are placed in the order of their original key setting. (This produces the same result as Create Multisample.)

1. In the Multisample Edit screen, press **[MENU]**.

The Multisample Edit Menu screen will appear.

2. Use **▲** or **▼** to select “Sort.”

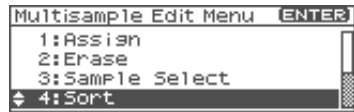

3. Press **[ENTER]**.

A screen will ask you for confirmation.

4. Press **[ENTER]**.

To cancel, press **[EXIT]**.

Returning a multisample to the last-written state (Reload)

Here’s how you can return the currently edited multisample to the state in which it was last written.

1. In the Multisample Edit screen, press **[MENU]**.

The Multisample Edit Menu screen will appear.

2. Use **▲** or **▼** to select “Reload.”

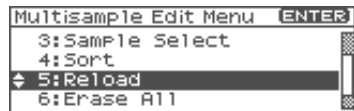

3. Press **[ENTER]**.

A screen will ask you for confirmation.

4. Press **[ENTER]**.

To cancel, press **[EXIT]**.

Erasing all notes (Erase All)

Here's how to erase all notes.

1. In the Multisample Edit screen, press [MENU].

The Multisample Edit Menu screen will appear.

2. Use ▲ or ▼ to select "Erase All."

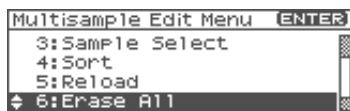

3. Press [ENTER].

A screen will ask you for confirmation.

4. Press [ENTER].

To cancel, press [EXIT].

Opening the Tone Select window (Tone Select)

1. In the Multisample Edit screen, press [MENU].

The Multisample Edit Menu screen will appear.

2. Use ▲ or ▼ to select "Tone Select."



3. Press [ENTER].

The Tone Select window will appear.

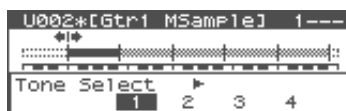

4. Press ◀ or ▶ to change the current tone.

5. Press [EXIT].

If you're using "Fantom-X Editor"

If you're using "Fantom-X Editor" you will also be able to use the following editing operations.

- Copy a sample from one note to another note (Copy)
- Move all samples to left or right (Shift)
- Move the data of the current zone to left or right (Move)

Saving a multisample

Once you've edited a multisample, the word "*" appears beside the multisample name. Be aware that if you turn off the power or select another screen when the "*" indication is shown, the changes you made to the multisample will be lost.

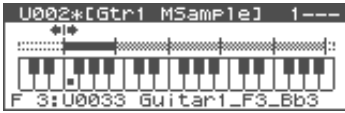

1. In the Multisample Edit screen, press [SHIFT] so it lights, and then press .

The Multisample Name window will open.

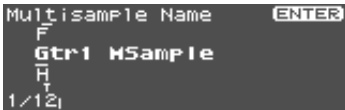

2. Assign a name to the multisample.

* For details on how to assign a name, refer to "Assigning a Name" (Owner's Manual; p. 39).

3. When you've finished inputting a name, press [ENTER].

The write-destination group will appear.

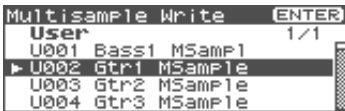

4. Turn the VALUE dial or use or to select the multisample number.
5. Press [ENTER].

A message will ask you to confirm the Write operation.

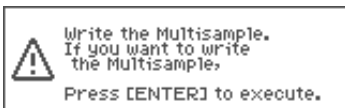

6. To write the data, press [ENTER].

To cancel, press [EXIT].

NOTE

Never turn off the power while data is being written.

Sample-related changes

Extended patch groups

You can now select samples (card/user) from the patch list as well (Sample Auto Patch). This allows you to play a sample in a pitched manner just as you would play a normal patch.



The following two groups have been added to the patch groups. If there are samples in memory, sample names will be displayed as patch names.

User Sample (USAM): 1–2000

Samples in user memory can be used as patches.

Card Sample (CSAM): 1–7000

Samples in the memory card can be used as patches.

- * In the Performance Play screen and Performance Part screen, these are shown as User Sample (USM) and Card Sample (CSM).
- * If there are no samples in memory, this will indicate "Empty."
- * In the case of a stereo sample, choose the sample number for the L channel. It will play as a stereo patch. (If you choose the sample number for the R channel, "---" will be indicated for it, and it will not be playable.)

Saving a sample auto patch

When you edit and save these patches, they will be saved in the USER or CARD group in the same way as conventional patches.

- * Note that in this case, there will be no sound if you unload (Owner's Manual; p. 121) the sample.
- * Unsaved samples will be lost when you turn off the power. If you want to keep your sample, be sure to save the sample (Owner's Manual; p. 131).

Bank Select and Program Change Correspondence Chart

Group	Number	Bank Select		Program Number
		MSB	LSB	
PR-1	001-128	87	72	1-128
USAM	0001-2000	64	0	1-128
			:	
			14	1-80
CSAM	0001-7000	65	0	1-128
			:	
			53	
			54	1-88

Newly added sample parameters

The following sample parameters have been added.



Owner's Manual; p. 123

U0001 [User 0001]	
▲Loop Start Fine	0
Loop End Fine	0
Sample Gain	+6
Sample Fine Tune	0
Sample Level	127

- **Sample Gain**

This adjusts the gain of the sample, letting you boost the volume if it decreased in the process of sampling.

Value: 0, +6, +12 [dB]

- **Sample Fine Tune**

This adjusts the pitch of the sample in steps of one cent (over a range of +/-50 cents).

Value: -50~+50

MEMO

1 cent = 1/100th of a semitone

- **Sample Level**

This adjusts the volume of the sample.

Value: 1-127

Changes due to the upgraded editor software

The included “Fantom-X Editor” software has been upgraded, allowing you to use an editor program to edit samples and multisamples.

Newly added PC mode screen

In conjunction with the addition of the sample editor, a PC mode screen has been added to the FANTOM-XR.

When you start up the sample editor, the FANTOM-XR will automatically enter PC mode, and will be inoperable using its own controls. This ensures that operations on your computer and on the FANTOM-XR will not interfere with each other.



When you close the editor on your computer, the FANTOM-XR will exit PC mode and return to the normal screen.

MEMO

The Fantom-XR will also enter PC mode when you execute a Write operation from the librarian (p. 24).

NOTE

When you must exit PC mode due to unavoidable circumstances, such as when your computer has frozen, you can do so by pressing [EXIT]. A screen will ask you for confirmation. Press [ENTER] to force the FANTOM-XR to return to the normal operation screen.

Cautions when using S-700 series sounds with the FANTOM-XR

The new editor adds a Fantom-X Sample Converter, which converts S-700 series patches/partial/samples into a form that can be read by the Fantom-XR. When loading S-700 series files you converted using this converter from your computer via USB into the Fantom-XR, please be aware of the following points.

Before you connect the FANTOM-XR to your computer

In order for S-700 series sound data files converted by Fantom-X Sample Converter to be loaded from your computer via USB, the Fantom-XR must be in Storage mode. The power will be turned off in the course of changing System settings, so make sure that you save any unsaved data before switching to Storage mode. For details on how to make this change, refer to “Switching the Storage Mode and the MIDI Mode” (p. 148) in the Owner’s Manual.

* *You don’t need to perform this operation when loading data from a card without using the USB.*

NOTE

You must switch the USB mode (Storage mode/MIDI mode) before you connect the FANTOM-XR to your computer.

For details on using USB Storage mode, refer to “Transferring Files to or from Your Computer (Storage Mode)” (p. 149) in the Owner’s Manual.

Importing patches and rhythm sets

Here's how patches, rhythm sets, multisamples, and samples placed in the following directory using Fantom-X Sample Converter can be imported into the FANTOM-XR.

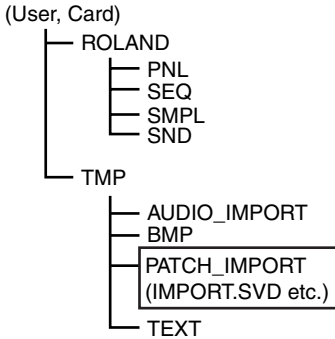

* If you used Fantom-X Sample Converter only to convert partials or samples, load them using Import Audio. (Owner's Manual; p. 121)

* If this directory does not exist, use your computer to create it.

1. In the Patch Play screen (Owner's Manual; p. 40) or the Performance Play screen (Owner's Manual; p. 84), press [MENU].

The Top Menu screen will appear.

2. Press ▲ or ▼ to select "Utility," and then press [ENTER].

The Utility Menu screen will appear.

3. Press ▲ or ▼ to select "Import Patch/Rhythm," and then press [ENTER].



The Import Patch/Rhythm screen will appear.

* From this point onward, the screens are shown in "wizard" format to guide you through the process.

4. The screen will indicate STEP 1.

The FANTOM-XR will check whether there are any files that can be imported. If such files are found, the number of Patches/Rhythm Sets/Multisamples that can be imported from User and/or Card will be displayed. Press [GROUP] to select the group containing the file you want to load.

USER: User

CARD: Memory card

* If there is no data that can be loaded, the "Import File Not Found" message will appear. If neither User nor Card contains data that can be imported, press [EXIT] to cancel the operation, and use Fantom-X Sample Converter to place the appropriate data where needed.

5. Press [ENTER].

6. STEPS 2–4 will appear.

Turn the VALUE dial or use [INC][DEC] or ▲ ▼ to select the starting number of the write destination for patch, multisample, and rhythm set respectively. (The user or card data will be overwritten by the imported data.)

NOTE

If you specify a high number as the starting number, the imported patches, rhythm sets, and/or multisamples may exceed their maximum numbers, making them impossible to import the remains. In this case the display will indicate "USER 256 - ***" in step 8.

NOTE

You can't change the write-destination group (User/Card). It will be the same as the loaded group. Sample data will be assigned automatically to numbers at the write destination.

MEMO

If there is no data to import, a screen like the following will appear. Press [ENTER] to proceed.



7. Press [ENTER].

MEMO

You can press [EXIT] to return to the preceding step.

8. STEP 5 will appear.

This screen shows details about the patch being imported.



If you are satisfied with what the screen shows, press [ENTER] to begin the import.

MEMO

You can press [EXIT] to return to the preceding step.

9. A screen like the following is shown during the import.



NOTE

Never turn off the power while data is being imported.

NOTE

If some of the data being imported is missing, the error message "File Not Found" will appear. In this case, delete all of the files in the PATCH_IMPORT folder, and use Fantom-X Sample Converter to replace the data.

10. When the import is completed, you are asked whether you can delete the source files located in the User or Card PATCH_IMPORT directory.

Press [ENTER] to delete the files. (To cancel, press [EXIT].)

* *It may take some time for files to be deleted.*

MEMO

If the Import was successful, there is normally no need to keep the source file.

11. Press [ENTER] to return to the normal screen.

12. Save the sample.

Unlike patches, rhythm sets, and multisamples, samples are not saved automatically when the import procedure finishes. You must save samples as described in "Saving samples (Save All Samples)" (p. 24) of the owner's manual.

* *In some cases, an imported patch, rhythm set, or sample may sound differently than when played back on the S-700 series.*

Fantom-X Editor System Requirements

If you're using Fantom-X Editor version 2.0 or later, please refer to the following.

System Requirements (Windows)

- **Operating System**
 - Microsoft® Windows® 98
 - Microsoft® Windows® Me
 - Microsoft® Windows® 2000 Professional
 - Microsoft® Windows® XP
 - **CPU/Clock:**
 - Pentium®/Celeron™ processor 400 MHz or higher
 - Pentium® III 500 MHz or higher (recommended)
 - **Memory (RAM)**
 - 128 MB or more
 - 256 MB or more (recommended)
 - **Hard Disk**
 - 140 MB or more
 - **CD-ROM Drive**
 - Built-in CD-ROM drive (IDE)
 - **Display/Colors**
 - 800 x 600 or higher /65,536 colors (16 bit High Color) or more
 - 1024 x 768 or higher (recommended)
- * *Microsoft and Windows are registered trademarks of Microsoft Corporation.*
- * *Windows® is known officially as: "Microsoft® Windows® operating system."*
- * *Pentium is a registered trademark of Intel Corporation.*

System Requirements (Mac OS)

- **Operating System**
 - Mac OS (Classic) 8.6 and 9.x
 - Mac OS (X) 10.2 and 10.3
 - **CPU/Clock**
 - PowerPC G3 233 MHz or higher (Classic)
 - PowerPC G3 500 MHz or higher (X)
 - **Memory (RAM)**
 - 128 MB or more
 - 256 MB or more (recommended)
 - **Hard Disk**
 - 140 MB or more
 - **CD-ROM Drive**
 - Built-in CD-ROM drive (IDE)
 - **Display/Colors**
 - 800 x 600 or higher /32,000 colors or more
 - 1024 x 768 or higher (recommended)
 - **Others**
 - OMS 2.0 or later (Classic)
- * *Apple and Macintosh are registered trademark of Apple Computer, Inc.*
- * *MacOS is a trademark of Apple Computer, Inc.*
- * *OMS is a registered trademark of Opcode Systems, Inc.*

Other changes

Changes in the librarian

cf.

Owner's Manual; p. 163

When using the Fantom-X librarian, you no longer need to manually select Librarian mode.

When Fantom-X Librarian begins to transmit the data, the Fantom-XR will automatically enter PC mode, and will no longer respond to operations performed on its control panel. This ensures that operations on the FANTOM-XR will not conflict with operations on your computer.



When you close the librarian on your computer, the FANTOM-XR will automatically exit PC mode and return to the normal operating screen.

NOTE

When you must exit PC mode due to unavoidable circumstances, such as when your computer has frozen, you can do so by pressing [EXIT]. A screen will ask you for confirmation, and you can press [ENTER] to force the FANTOM-XR to return to its normal operating screen.

Newly added DIMM check function

When you power up the FANTOM-XR, it will automatically check whether the DIMM memory (Owner's Manual; p. 170) is operating correctly.

If the DIMM contacts are faulty, a screen like the following will appear.

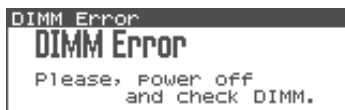

If this occurs, turn off the power immediately, and re-insert the DIMM memory correctly.

Saving samples (Save All Samples)

To save the samples, proceed as follows.

This procedure will save all samples and multisamples into user memory or a memory card.

1. In the **Sample Edit screen (Owner's Manual; p. 122) or the Sample List screen (Owner's Manual; p. 120)**, press [MENU].

The Sample Utility screen will appear.

2. Press ▲ or ▼ to select "Save All Samples."
3. Press [ENTER].

A screen will ask you for confirmation.

4. Press [ENTER] to execute.

To cancel, press [EXIT].

Samples are automatically overwritten into the same number of the same bank in the sample list. (The same applies to multisamples.)

Index

- A**
 - Assign
 - Multisample 14
- B**
 - Bank Select 18
- C**
 - Current zone 14
- D**
 - DIMM 24
- E**
 - Erase All
 - Multisample 16
 - Erasing
 - Multisample 14, 16
- F**
 - Fantom-X Sample Converter 20–22
 - FANTOM-XR Sample Tools Expansion Kit
7
- I**
 - Import Patch/Rhythm 21
 - Importing
 - Patch 21
- L**
 - Librarian 24
- M**
 - Multisample
 - Assign 14
 - Create Multisample Screen 12
 - Editing 13
 - Erase All 16
 - Erasing 14
 - Multisample List 14
 - Original Key 15
 - Patch Edit Screen 12
 - Reload 15
 - Sample Select 14
 - Saving 17
 - Sort 15
 - Tone Select 16
 - Multisample Edit Screen 13
 - Multisample List 14
- O**
 - Original Key
 - Multisample 15
- P**
 - Patch Group
 - Sample 18
 - PC Mode Screen 20
 - Preview 13
 - Program Change 18
- R**
 - Reload
 - Multisample 15

S

S-700 Series	20
Sample	18
Saving	18
Sample Auto Patch	18
Sample Fine Tune	19
Sample Gain	19
Sample Level	19
Sample Parameter	19
Sample Select	
Multisample	14
Save All Samples	24
Saving	
Multisample	17
Sample	24
Sample Auto Patch	18
Sort	
Multisample	15
Split Point	
Multisample	13

T

Tone Select	
Multisample	16

U

Updating	7
----------------	---

Z

Zone	14
------------	----